

F™ Series Fluid Temperature Sensing Valves



Your Key to Automatic
Freeze Protection and Fluid
Temperature Control



The Ogontz F™ Series Fluid Temperature Sensing Valve

Your key to automatic freeze protection & fluid temperature control

Maximum Performance, Minimum Cost

Benefits

- Easy installation, low installation costs
- Automatic fail-safe design
- Reliable, unattended operation
- Minimal maintenance requirements
- Eliminate costly freeze damage
- Reduce cost of seasonal open blocked valves
- Protect personnel from accidental scalding at emergency shower and eyewash stations
- Increased efficiencies in cooling water control

Design Features

- Fail-safe (direct acting valve opens)
- Self contained actuator: Solid/liquid thermal actuator requires no external power or remote signal
- In-line serviceability
- Insensitive to line pressure
- Valve port opens/closes gradually, preventing system shock
- High repeatability: No set point drift
- Temperature set points from 35°F to 255°F
- Available in line sizes from 1/2" to 2"
- 100% factory tested

Typical Applications

- Freeze Protection
- Anti-scald
- Glycol Systems
- Heat Exchangers
- Cooling Towers
- Sample Lines
- Sprinkler Systems
- Condensate Return
- Chillers
- Compressors
- Tanks
- Pumps
- Fire Lines
- Safety Showers

Self-Contained Thermal Actuator

The heart of the F Series valve is a unique, solid-liquid phase thermal actuator. This hydrocarbon wax-filled device actuates the valve in response to changes in temperature. The transition from solid to liquid phase causes a large change in volume, exerting a tremendous force over a narrow temperature band.

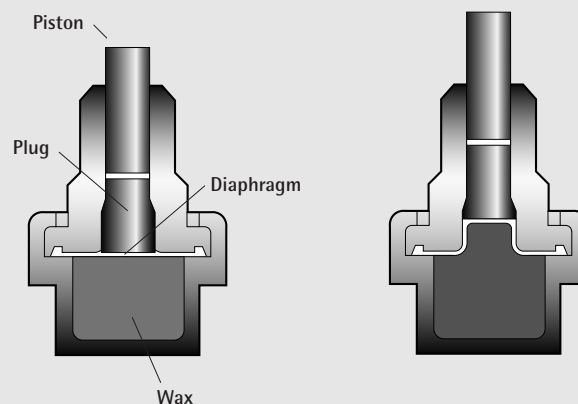

Cold Position

As fluid temperature drops below the preset temperature, the wax contracts, allowing the force of the operating spring to open a direct-acting valve or close a reverse-acting valve.

Hot Position

As fluid temperature rises above the preset temperature, the wax starts to expand, exerting force on the operating spring and closing a direct-acting valve, or opening a reverse-acting valve.

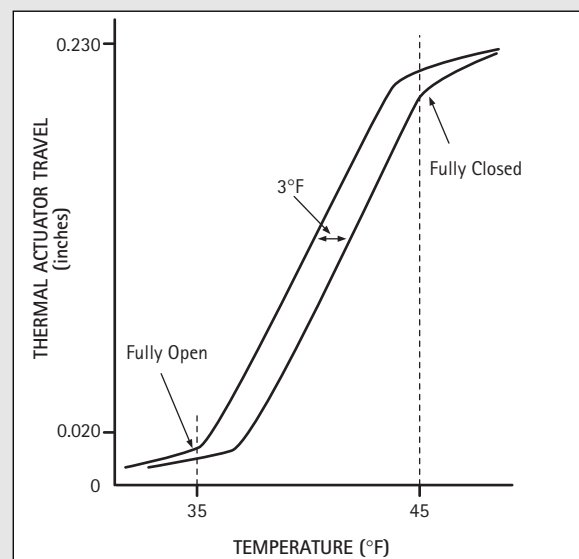

The limited hysteresis of the wax during changes in state from solid to liquid results in a narrow temperature dead band, providing very close control around the temperature set point.

F/FG Series Automatic Freeze Protection & Fluid Temperature Control

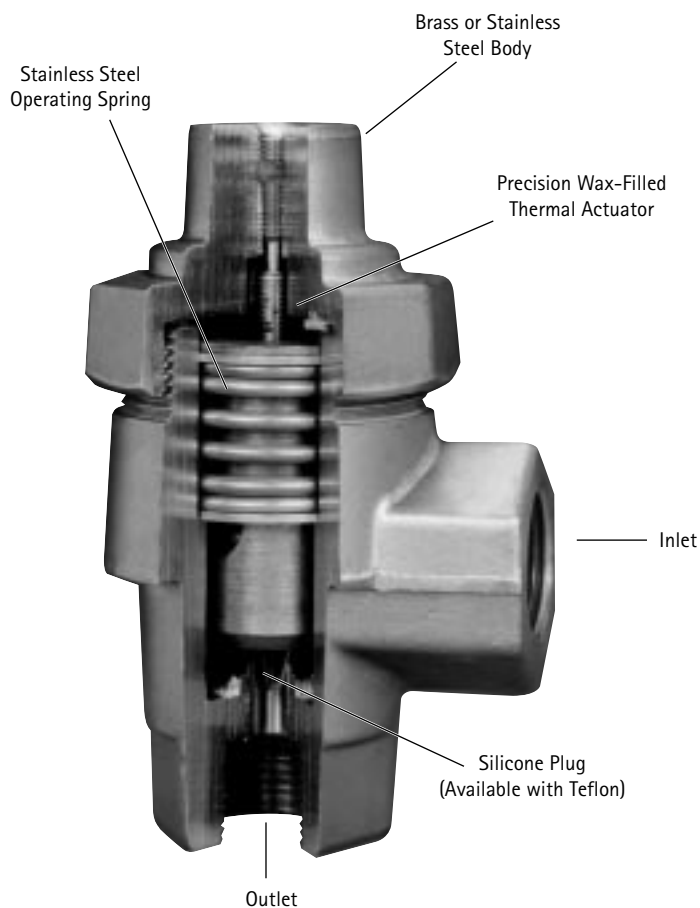

The F/FG series valve is the most economical way to protect outdoor pipelines and vessels from expensive freeze damage. A thermal actuator automatically opens the valve before the temperature of the fluid drops to the freezing point. By bleeding the fluid in the system only when the danger of a freeze-up exists, the valve delivers positive freeze protection with minimal waste. This intermittent operation provides substantial savings in water and sewer costs, making the F/FG series valve an ideal, economical replacement for systems with manually operated block valves that are opened seasonally. The F/FG series can also be used in most applications that involve automatic control of fluids, such as glycol, oil, light chemicals, etc.

Typical Applications

- Exposed Water Lines – indoors or outdoors
- Fire Lines
- Sprinkler Systems
- Ship Supply Lines
- Safety Showers
- Tanks
- Condensate Returns
- Cooling Towers
- Air Scrubbers

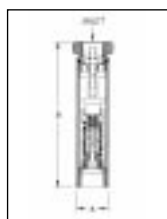

Figure A

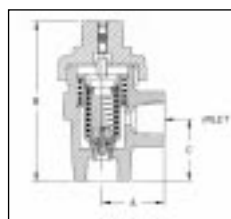

Figure B

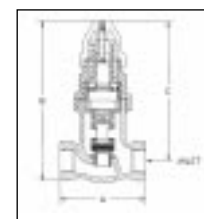

Figure C

F/FG Series Valve Selection Chart

Size (NPT)	Valve Type	Available Set Point Temperature ¹	Available Ports	Max Operating Pressure- ψ sig	C _v	Action ²	Body Material ³	Fig.	Dimensions $\pm 1/8$ "			Net Wt.
									A	B	C	
1/2"	F	35° to 240°F	B=1/4"	200	0.8	D	T	A	1 1/8"	5 1/4"	—	3/4 lb.
			A=1/8"	200	0.5	D	B,S	B	1 7/8"	4 3/4"	1 7/8"	2 3/4 lbs.
3/4"	F		B=1/4"	200	0.8	D	B,S	B	1 7/8"	4 3/4"	1 7/8"	2 3/4 lbs.
			C=3/8"	200	1.2	D	B,S	B	1 7/8"	4 3/4"	1 7/8"	2 3/4 lbs.
1/2"	FG		A=1/4"	150	1.6	D	B	C	3 1/2"	7 5/16"	6 1/4"	5 1/2 lbs.
			S				S	C	3 1/2"	7 5/16"	6 1/4"	4 3/4 lbs.
3/4"	FG		B=3/8"	150	3.0	D	B	C	3 1/2"	7 5/16"	6 1/4"	5 1/2 lbs.
			S				S	C	3 1/2"	7 5/16"	6 1/4"	4 3/4 lbs.
			C=1/2"	150	3.8	D	B	C	3 1/2"	7 5/16"	6 1/4"	5 1/2 lbs.
			S				S	C	3 1/2"	7 5/16"	6 1/4"	4 3/4 lbs.
1"	FG		A=1/2"	125	4.7	D	B,S	C	4 1/2"	7 5/16"	6 1/4"	6 3/4 lbs.
			C=3/4"	125	5.5	D	B,S	C	4 1/2"	7 5/16"	6 1/4"	6 3/4 lbs.
1 1/2"	FG	A=3/4"	200	6.4	D	B,S	C	6"	11"	9 1/8"	20 lbs.	
2"	FG	B=1"	150	8.8	D	B,S	C	6"	11"	9 1/8"	20 lbs.	
		C=1 1/2"	50	14.1	D	B,S	C	6"	11"	9 1/8"	20 lbs.	

1. Specify the desired full open set point temperature in 5°F increments.

2. Direct Acting - Closes on temperature rise. 3. B - Bronze. S - Stainless Steel. T - Tubular Stainless Steel.

Maximum flow rate for water with valve fully open: $GPM = C_v \sqrt{\Delta P}$

FP/FPR Series

Freeze/Scald Protection For Emergency Showers

The FP/FPR series valves feature a space-saving, in-line design and high/low temperature sensitivity to provide positive freeze/scald protection for emergency safety showers and eyewash stations.

Freeze Protection

The low temperature actuated FP series provides the same basic freeze protection as the F/FG series valves, but with a straight-through flow area larger than the pipe diameter for unrestricted flow.

Scald Protection

The reverse acting FPR series valve is actuated by temperatures in excess of 100°F due to overheating, direct sunlight or other heat source. Discharge stops when temperature drops below 90°F. Full flow to shower head is also assured.

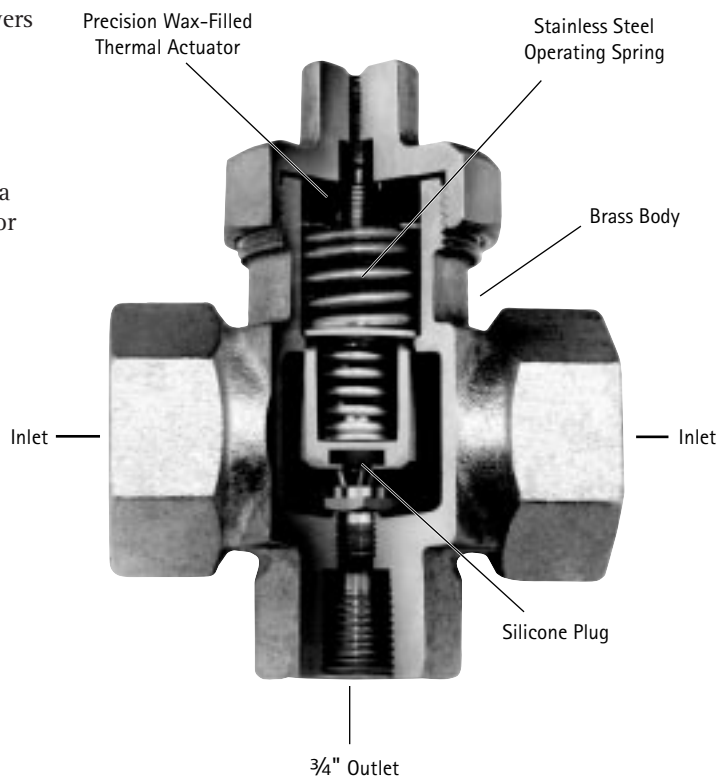
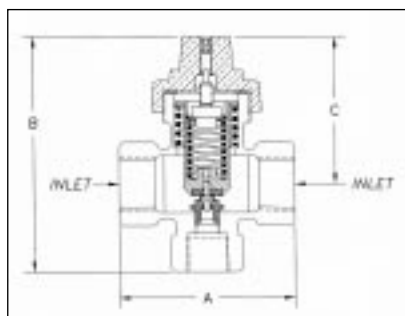

Figure A



FP/FPR Series Valve Selection Chart

Size (NPT)	Valve Type	Available Set Point Temperature ¹	Available Ports	Max Operating Pressure- ψ sig	C_v	Action ²	Body Material ³	Fig	Dimensions $\pm 1/8$ "			Net Wt.
									A	B	C	
1"	FPR	35° to 255°F	B=1/4"	200	1.0	R	B	A	4 1/4"	5 1/4"	2"	4 lbs.
	FP		C=3/8"	200	1.2	D	B	A	4 1/4"	5 1/4"	2"	4 lbs.
	FPR		C=3/8"	50	1.4	R	B	A	4 1/4"	5 1/4"	2"	4 lbs.
1 1/4"	FPR	35° to 255°F	B=1/4"	200	1.0	R	B	A	4 1/4"	5 1/4"	2"	4 lbs.
	FP		C=3/8"	200	1.2	D	B	A	4 1/4"	5 1/4"	2"	4 lbs.
	FPR		C=3/8"	50	1.4	R	B	A	4 1/4"	5 1/4"	2"	4 lbs.

1. Specify the desired full open set point temperature in 5°F increments.

2. Direct Acting – Closes on temperature rise.
Reverse Acting – Closes on temperature fall.

3. B – Bronze.

Maximum flow rate for water with valve fully open: $GPM = C_v \sqrt{\Delta P}$

Compliance: Helps meet ANSI Z358.1-1998 (section 9.4.5) in scald protection application.

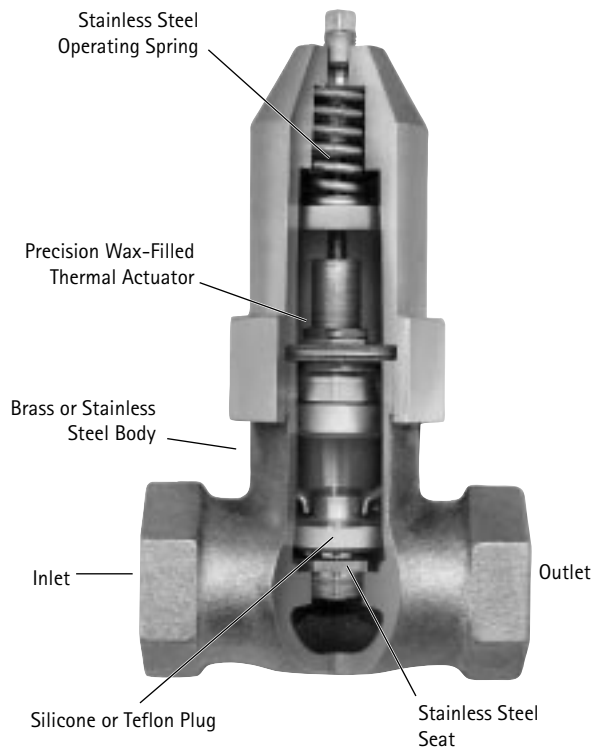

FR/FGR Series Automatic Control for Cooling Systems

The reverse-acting FR/FGR series valve is an inexpensive way to maintain optimum discharge temperatures for more efficient and economical use of your cooling media. Because of its reverse action design, the valve closes when fluid temperature drops below a preset temperature – effectively eliminating the inefficient discharge of low temperature cooling fluid.

Controlled leakage* can be provided through the valve for constant, true temperature monitoring. The FR/FGR series valve is an economical way to maintain optimum operating temperature of equipment for maximum efficiency.

Typical Applications

- Compressor Cooling Water
- Heat Exchangers
- Engine Cooling Water
- Cooling Drums or Rolls
- Platens
- Any other application requiring removal of heat with any circulating fluid compatible with bronze or stainless steel
- Scald protection for emergency safety shower

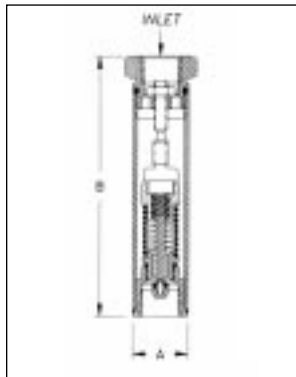

Figure A

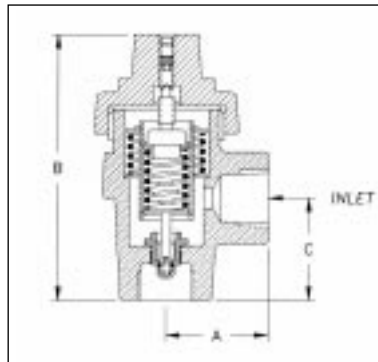

Figure B

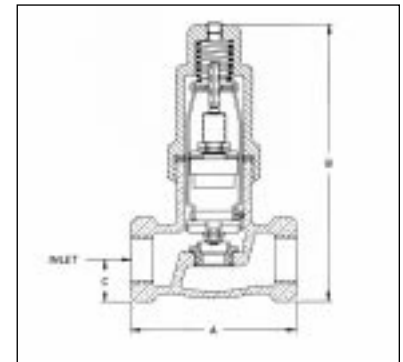

Figure C

FR/FGR Series Valve Selection Chart

Size (NPT)	Valve Type	Available Set Point Temperature ¹	Available Ports	Max Operating Pressure-psig	C _v	Action ²	Body Material ³	Fig No.	Dimensions ± 1/8"			Net Wt.
									A	B	C	
1/2"	FR	45° to 255°F	B=1/4"	200	0.5	R	T	A	1 1/8"	5 1/4"	—	3/4 lb.
3/4"	FR		B=1/4"	200	0.5	R	B,S	B	1 7/8"	4 3/4"	1 7/8"	2 3/4 lbs.
			C=3/8"	80	0.9	R	B,S	B	1 7/8"	4 3/4"	1 7/8"	2 3/4 lbs.
1/2"	FGR		A=1/4"	200	1.6	R	B,S	C	3 1/2"	6 3/8"	7/8"	5 lbs.
3/4"	FGR		B=3/8"	200	2.7	R	B,S	C	3 1/2"	6 3/8"	7/8"	5 lbs.
			C=1/2"	200	3.8	R	B,S	C	3 1/2"	6 3/8"	7/8"	5 lbs.
1"	FGR	A=1/2"	150	4.7	R	B,S	C	4 1/2"	6 3/8"	1 5/32"	6 1/4 lbs.	
		C=3/4"	150	5.3	R	B,S	C	4 1/2"	6 3/8"	1 5/32"	6 1/4 lbs.	
1 1/2"	FGR	A=3/4"	150	6.4	R	B,S	C	6"	6 5/8"	1 3/4"	18 lbs.	
2"	FGR	B=1"	100	8.8	R	B,S	C	6"	6 5/8"	1 3/4"	18 lbs.	
		C=1 1/2"	50	14.1	R	B,S	C	6"	6 5/8"	1 3/4"	18 lbs.	

1. Specify the desired full open set point temperature in 5°F increments. 2. Reverse Acting - Closes on temperature fall. 3. B – Bronze. S – Stainless Steel. T – Tubular Stainless Steel. Maximum flow rate for water with valve fully open: $GPM = C_v \sqrt{\Delta P}$

*Optional standard leak ports available with reverse action valve. See "How To Order" section.

Ogontz At Work For You

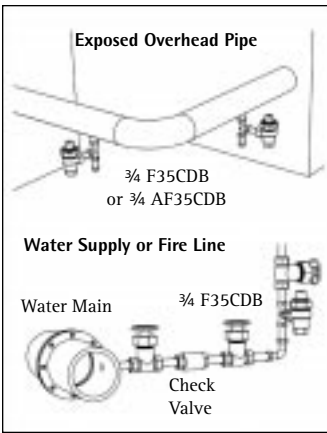

Winterization of Exposed Overhead Pipe

Use an F series valve to winterize an exposed overhead pipe and freeze-protect a water supply or fire line. *Please note this is only for the internal sensing of fluid temperature.*

An AF series can be used to bleed fluid from an exposed water line when external air temperature drops toward freezing, thus preventing ice from forming and blocking fluid flow. Consult AF series literature.

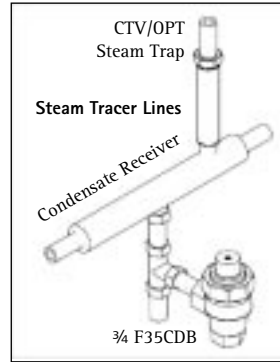

Freeze Protection of a Condensate System

Installed on a condensate receiver, the F series valve provides positive freeze protection by draining the condensate system when fluid temperature approaches a preset critical temperature.

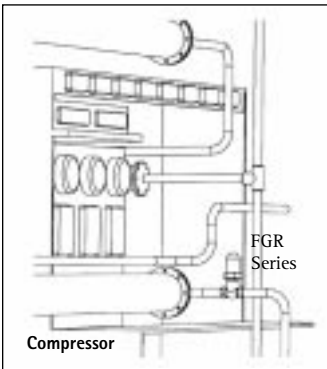

Freeze & Scald Protection of a Water Cooled Air Compressor

FGR series valve installed on water cooled compressor. The FGR valve senses cooling water outlet temperature and throttles to maintain optimum compressor temperature. Thus, water consumption is minimized and equipment life maximized.

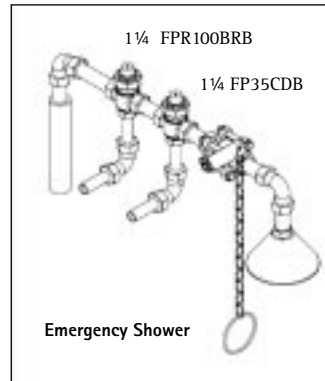

Freeze & Scald Protection for an Emergency Shower

Installation of FP and FPR series valves (direct and reverse acting) provides both freeze and scald protection for emergency showers and eyewash stations.

How To Order

1/2	F	35	B	D	T
-----	---	----	---	---	---

Size (NPT)
Specify:
1/2, 3/4, 1, etc.

Valve Type
Specify F, FG, FP, FPR, FR, FGR

Temperature To Fully Open
Specify temperature between 35° and 255°F in 5°F increments. Differential from full open to full closed is typically 10° to 15°F. Valve opens/closes gradually.

Body Material
Specify:
B = Bronze
S = Stainless Steel
T = Tubular Stainless Steel

Valve Action
Specify:
D = Direct
R = Reverse

Port Size
Specify:
A, B, or C, per the Valve Selection Chart

Suffix for Reverse Action Valves

We can supply reverse action valves with optional standard leak ports. Add "L" with "X" or "Z" port size as suffix to part number (example: 1FR100CRB-LX)
LX - 1/4 to 1/2 GPM at 60 PSIG
LZ - 1/2 to 1 GPM at 60 PSIG
Consult your distributor for additional leak port requirements.

Principle of Operation

Specify a full open set point in 5°F increments

Valve will slowly actuate within a 15°F differential of specified set point.

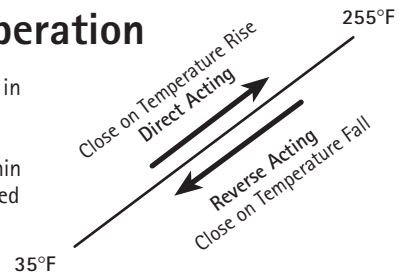

The Ogontz Guarantee

We will repair or replace on a no-charge basis, FOB Willow Grove, PA, any valves or traps returned to us within 18 months, if found to be defective in material or workmanship.

2835 Terwood Road • Willow Grove, PA 19090 USA
800/523-2478 • 215/657-4770 • Fax: 215/657-0460
www.ogontz.com • info@ogontz.com



North America • South America • Europe • Asia
Copyright Ogontz Corporation, 2003 • Bulletin #9-03